



THE NEXT GENERATION OF FLEXIBILITY

Operable PARTITIONS

SERIES 600 FEATURES

FOUR-FINGER, MULTIPLE CONTACT SWEEP SEALS

“QUICK-SET” TOP AND BOTTOM MECHANICAL SEALS

STANDARD 1" TOP AND 2" BOTTOM CLEARANCES (DEEPER BOTTOM CLEARANCES OPTIONAL ON SINGLE 4" THICK PANELS)

WELDED, HEAVY-DUTY 16-GAUGE STEEL FRAME

PROTECTIVE VERTICAL EDGE TRIM OR OPTIONAL MONOLITHIC EDGES

GYPSUM AND STEEL ACOUSTICAL FACES WITH TACKABLE SURFACE OPTIONS

STANDARD VINYL. OPTIONAL FABRIC, CARPET AND CUSTOM FINISHES MAY ALSO BE APPLIED

WAIST-HIGH SEAL ACTIVATOR FOR FAST, EASY SETUP

DEEP NESTING, VERTICAL BULLNOSE/ ASTRAGAL SYSTEM



top to bottom:

Customized bottom seals enable these panels to seal against the steps when this University auditorium requires simultaneous sessions.

The beautifully detailed wood veneer faces on these movable panels match the perimeter walls in this upscale restaurant.

Electrically operated partitions easily convert this gymnasium into three classrooms. The Hufgard protection system stops the partition should people or objects obstruct the partition during movement.

This Georgia hotel uses Hufcor omni-directional panels to create multiple meeting spaces. Additional runs of transfer track allow the staff to move the panels without disturbing meetings in progress.

OPERABLE PARTITIONS SPECIFICATIONS

Operable

Panel Construction

Panels are a nominal 3" [76] or 4" [102] thick. Panel faces are laminated to the appropriate substrate to meet the STC requirement. Welded frames are of 16 gauge [1.42mm] steel with integral factory applied aluminum vertical edge and face protection. (Optional: no protective vertical face trim for a monolithic look.) Vertical sound seals are of tongue and groove configuration to ensure panel-to-panel alignment and prevent sound leaks between panels. Hinges for pairs or continuously hinged models are recessed and project no more than 1/4" [6] from the panel face.

Seals

Paired & Individual: horizontal top seals are retractable, provide 1" [25] nominal operating clearance, and exert upward force when extended. All panels, including pass door panels and lever closure panels have retractable top and bottom seals. 3" models have standard fixed (sweep) dual 4-finger vinyl top seals but retractable top seals are optional.

Horizontal bottom seals are retractable, provide up to 2" [50] nominal operating clearance and exert downward force when extended. 4" [102] bottom clearance is an available option on Model 641. Automatic bottom seals are optional for 3" single and paired models.

Continuously Hinged (Trains): Electric continuously hinged models have fixed top seals and retractable bottom seals. Fixed bottom seals are an option. 633 manual continuously hinged models have top and bottom fixed seals.

Finishes

The standard face finish is factory-applied vinyl; however, optional carpet, fabric, wood veneers and other custom finishes are available on most models. Panels may also be unfinished for field decoration. The metal trim is powder coated and the matching vinyl seals are available in Lamb's Wool, Gray, or Brown. Custom metal trim colors are available. If a custom trim color is selected, the vinyl sound seals will be furnished in Gray, Brown or Lamb's Wool.

Suspension System

Hufcor track systems have been life-cycle tested for up to 100 miles [161] or approximately 10 years of use.

Acoustics

The partition has been tested in accordance with ASTM E90. A complete, unedited written test report is available upon request. See charts for STC ratings.

ISO Registration

Hufcor U.S. manufacturing facilities' quality systems are registered to the ISO 9001 standards.

Fire-Rated 600-F

One-hour fire rated partitions are available in pairs and single panel models and are identified with an "F" following the model number. They are the same basic construction as the Series 600 and may be finished with any standard Hufcor vinyl, fabric, carpet or any vinyl having a UL Label of 15 or less flame spread. Panel faces may be painted or shipped unfinished for field decoration. The local fire marshal must approve any field applied surface material.

The partition closure must be by lever closure panel which terminates in either a wall recess of a minimum 1-3/8" [35] in depth or surface wall jambs not to exceed 1-3/8" [35] protrusion.

Fire-rated panels are listed as a one-hour Special Purpose Fire Door assembly, tested to UL 10B, ASTM E152 or NFPA 252 standards. The listing includes all variations of the panel configuration, tracks, hardware, end conditions, options, finishes and pass doors contained in the project design.

Warranty

Series 600 and 600-F partitions are guaranteed for two years against defects in material and workmanship, excluding abuse.

Details and editable specifications can be downloaded from Hufcor's website, www.hufcor.com. Complete specifications and details may also be found in our Architectural Product Manual.

630 SERIES STC & Hanging Weights

Models	Sound ¹ Transmission Class (STC)	Hanging Weight ² Lbs./Sq.Ft. [Kg./Sq.M]
631/632/633	51	10.2 [49.8]
631/632/633	49	8.9 [43.5]
631/632/633	47	7.8 [38.1]
631/632/633	43	7.3 [35.6]
631/632/633	41	5.7 [27.8]

640 SERIES STC & Hanging Weights

Models	Sound ¹ Transmission Class (STC)	Hanging Weight ² Lbs./Sq.Ft. [Kg./Sq.M]
641/642/643	54	10.9 [53.2]
641/642/643	52	9.5 [46.0]
641/642/643	49	8.5 [41.2]
641/642/643	47	8.0 [38.7]
641/642/643	43	7.8 [37.8]

¹ Sound Transmission Class (STC). Not all substrates are available for all STCs.

² Estimated standard panel weight. Weight will vary based on size, substrate and options. Allow approx. 3.6 lbs./lin. ft. [5.3 kg/m] for track. Add 140 lbs. [63 kg] for pass door; add 5 lbs./lin. ft. [7.4 kg/m] of height for Lever Closure Panel. Weights are calculated for a single line of panels only.

630 SERIES Stack Sizes

Configuration	Model(s)	Nominal Stack Depth
Paired	632	3-3/4" [95] per panel + 1" [25] (for Type 38 track) 4" [102] per panel + 1" [25] (for Type 40, 11 track) ¹
Individual (Omni)	631	3-3/4" [95] per panel + 1" [25] ¹
Continuously Hinged (Train)	633 (manual) 633E (electric)	4" [102] per panel + 8-1/2" [216]

640 SERIES Stack Sizes

Configuration	Model(s)	Nominal Stack Depth
Paired	642/642F	4-1/4" [108] per panel + 1" [25] ^{1, 2}
Individual (Omni)	641/641F	4-1/4" [108] per panel + 1" [25] ^{1, 2}
Continuously Hinged (Train)	643E (electric)	4-1/4" [108] per panel + 8-1/2" [216]

¹ Stack size shown is for retractable bottom seals. Use of optional face material may increase stack dimensions.

² For fire rated models, add 1-1/2" [38] in lieu of 1" [25].

Note: Metric dimensions are in []

Operable Partitions

SERIES 600

Operable Partitions, also referred to as “airwalls” or flat panels, deliver unlimited space division and acoustical separation. Choose from paired or continuously hinged models for wall-to-wall space separation or single panels for optimum room flexibility. As the world’s leading manufacturer of partitions, we have models for every budget and need. For facilities with special requirements, our engineering department can make recommendations or custom design partitions.

The Hufcor 600 Series operable partition is the most versatile and aesthetically pleasing operable wall constructed today. It combines the durability of a welded steel frame with the design versatility of various acoustical and decorative face constructions.

The panel design enables the 600 series to be manufactured with Hufcor’s quick-set mechanical top and bottom seals that provide the most reliable and fastest in-field operation. Hufcor’s time-tested protective edge trim is standard on both the 3” and 4” thick models yet both can be supplied with a monolithic, untrimmed edge. The deep nesting, interlocking bullnose/astragal and integrated seals provide a reliable vertical seal that keeps out sound.

Trim Colors – Standard

The 600 Series is available in three standard trim colors – Lamb’s Wool, Brown or Gray. Custom colors for metal trim are also available for an upcharge.

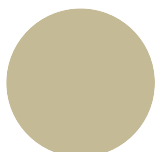

Lamb’s Wool

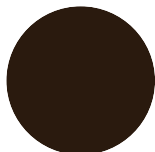

Brown



Gray

Pass Door Features

Hufcor’s pass door has been designed to provide optimal in-field performance. Features include:

- Rigid steel truss frame for durability
- ADA compliant push-pull door hardware
- Protective edge trim for durability and visual requirements identified by International Building Code
- Perimeter compression seals
- No exposed fasteners on inside of door frame
- Positive latching door hardware
- Edge activated bottom seals with downward seal force to stabilize door in opening
- Door leaf compensates for floor variances with a field adjustable mechanical bottom seal

Model Number Chart

When specifying the Hufcor 600 series, simply choose performance features – STC rating, seal system, trim color, protective edge trim, pass doors, finishes – as needed on the project. Our model numbers are easy to understand once you know the code (see the code chart below).

MODEL NUMBER CHART

First Digit 6: 600 Series

Second Digit 3 or 4:
3” or 4” thick panels

Third Digit:
1 for single models; 2 for paired models; 3 for continuously hinged (train) models

Fourth Digit:
E for Electric operation;
F for Fire-Rated

1st Digit	2nd Digit	3rd Digit	4th Digit	Model Number
Series	Panel Thickness	Configuration	Optional Code for Special Requirements	Model Number
6	3" [76]	Single Panels		631
6	3" [76]	Paired Panels		632
6	3" [76]	Continuously Hinged (Train)	E = Electric Operation	633, 633E
6	4" [101]	Single Panels	F = Fire Rated Model Available	641, 641F
6	4" [101]	Paired Panels	F = Fire Rated Model Available	642, 642F
6	4" [101]	Continuously Hinged (Train)	E = Electric Operation	643E

Note: Metric dimensions are in []

OPERABLE PARTITIONS SPECIFICATIONS

600 SERIES SECTIONS

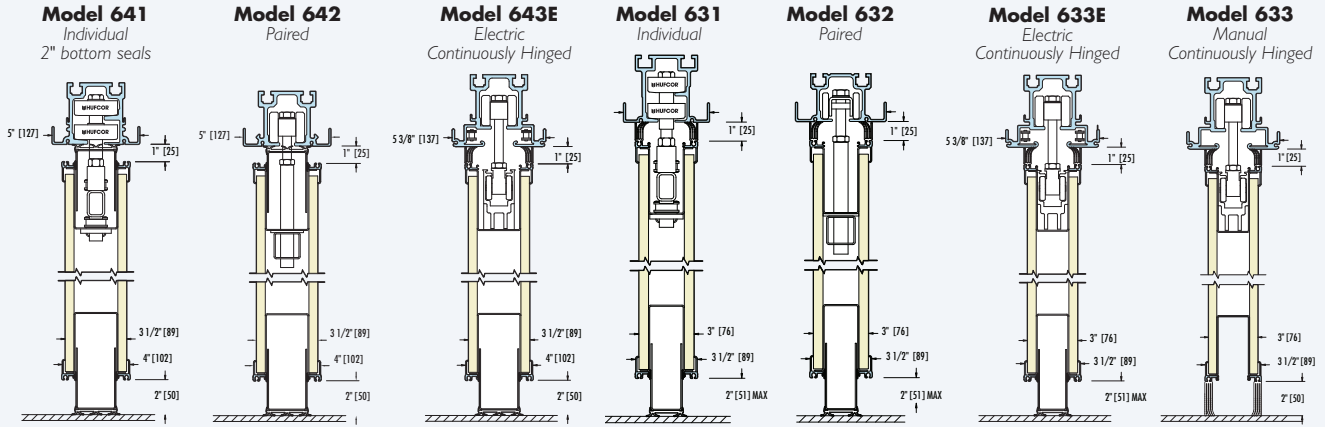

600 HORIZONTAL & OPTIONAL SECTIONS

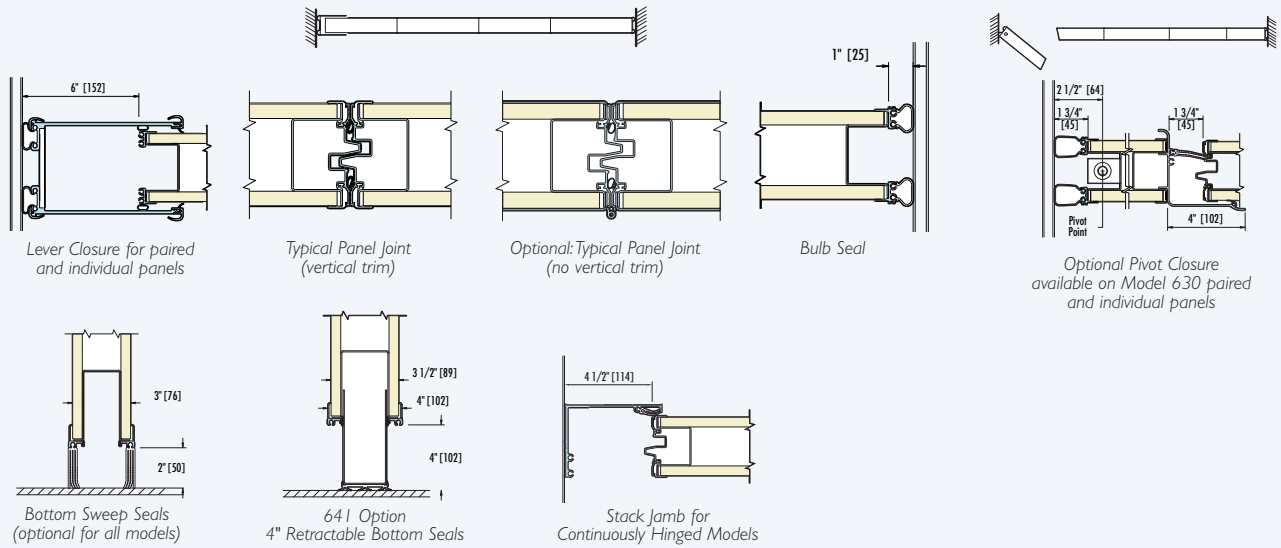

600-F FIREWALL SECTIONS

600-F FIREWALL HORIZONTAL SECTIONS

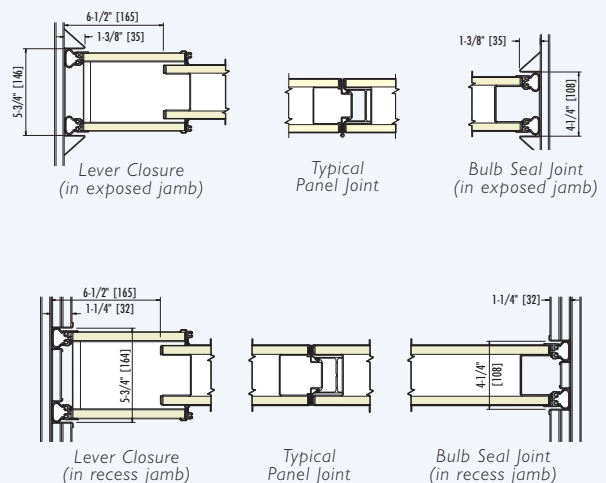
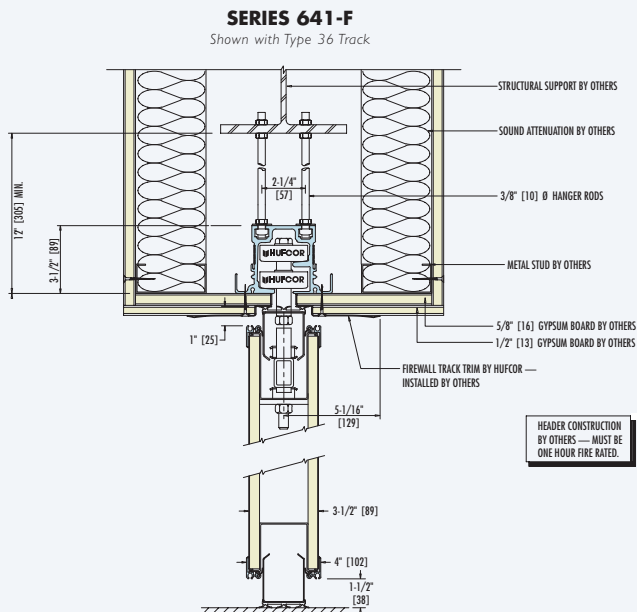

Note: Metric dimensions are in []